



Safer by design.
The JCB Teletruk Logistics Range.



Unrivalled visibility.

JCB Teletruk. The world's only telescopic counter balance forklift has been built to meet the demands of the logistics sector. The Teletruk's unique side mounted boom design provides unrivalled forward visibility.



Single Side Loading.

The Teletruk's unique telescopic forward reach allows you to load and unload trucks from one side. This means less forklift movements are required; load areas can be half the size verses double side loading. Also, on-site safety is revolutionised by and removing the need to push or pull items across the lorry bed. In this customer's goods in/out setup, two Teletruk's load/unload 80 to 90 trucks each day.

Using JCB Teletruk's instead of standard forklifts, there is no need to travel around the blind side of the lorry improving on-site safety.

225m² space saved by being able to single side load and unload with the JCB Teletruk.





Load fallen.



Load recovered and straight.

One hundred and eleven degrees of carriage rotation.

This unique benefit makes handling goods much easier and safer.

The Teletruk can also easily recover tipped or fallen loads, removing the requirement for manual handling.



Forward reach.

The Teletruk's unique telescopic forward reach allows you to reach to the load you want in the first, second or third row. All lifts are protected by JCB's load motion control system aiding in the prevention of forward tip.



Load Motion Control System.



Van Loading.

Save time by loading and unloading directly into delivery vans with the Teletruk's forward reach of up to 2.4m. The Teletruk removes the risk of material and vehicle damage and eliminates the risk of injury from manual handling loads into vehicles.



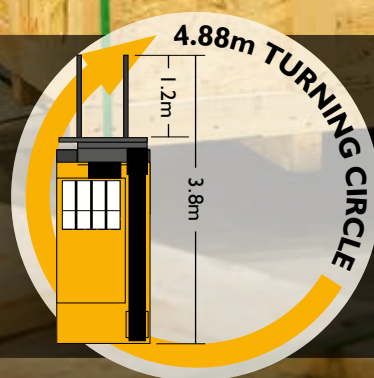
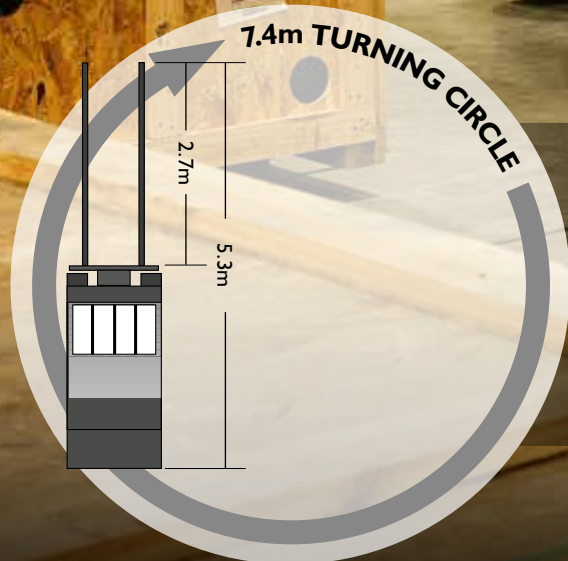

Compact and manoeuvrable.

The combination of a telescopic boom with small footprint and turning radius makes the Teletruk the world's most versatile counterbalanced lift truck. With the boom retracted the JCB Teletruk has a turning radius of just 2.4m compared with a standard forklift with fork extensions at 3.7m.

Ramping Performance.

The Teletruk's compact footprint and powerful hydrostatic transmission results in excellent performance up ramps and gradients. Making it even more productive.





First choice for containers.

With a cab height of only 2.2m and full free lift as standard, the Teletruk logistics range can all easily and safely load and unload inside a container.

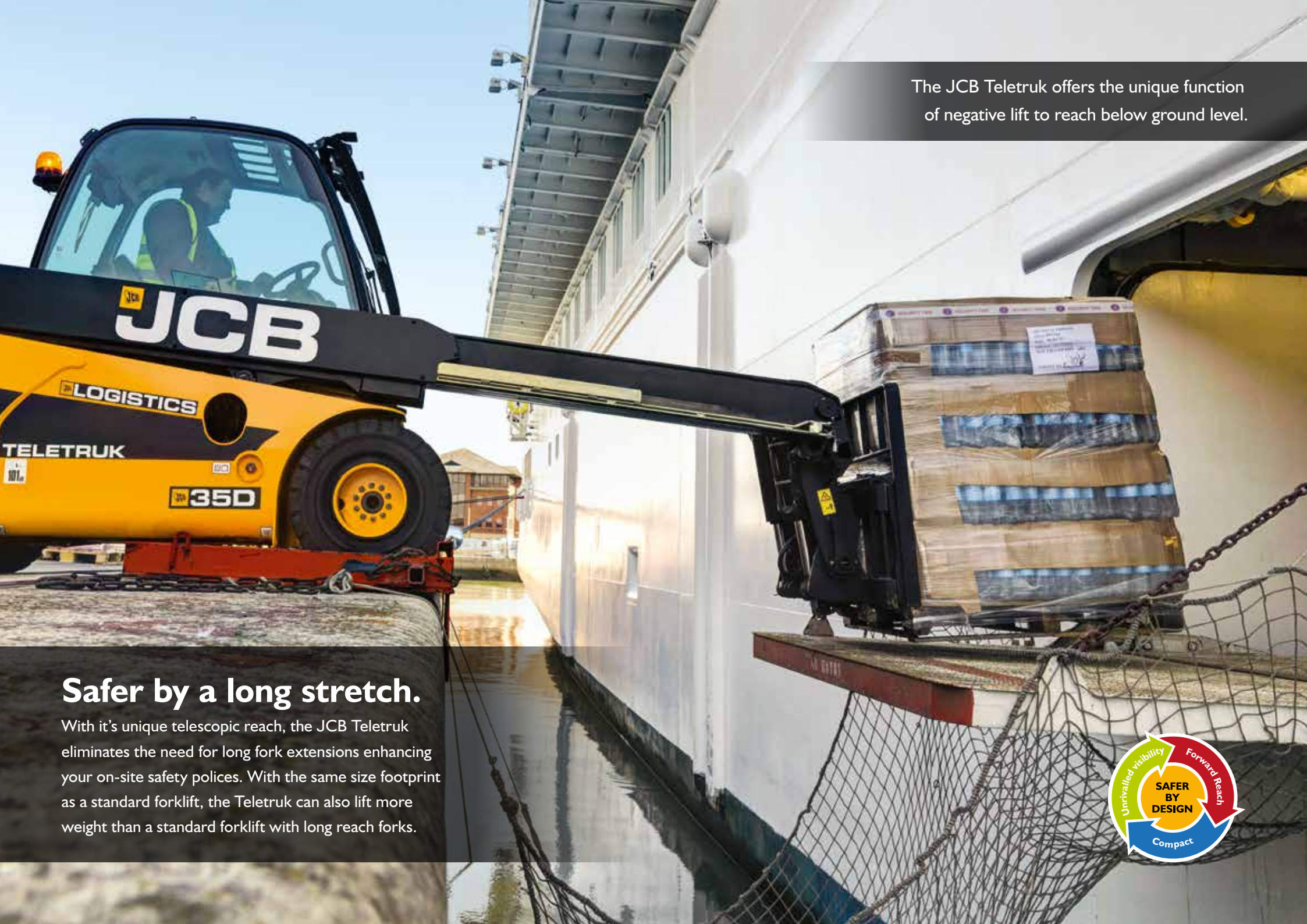

The JCB Teletruk offers the unique function of negative lift to reach below ground level.

Safer by a long stretch.

With its unique telescopic reach, the JCB Teletruk eliminates the need for long fork extensions enhancing your on-site safety policies. With the same size footprint as a standard forklift, the Teletruk can also lift more weight than a standard forklift with long reach forks.





Environment.

The latest clean burn Tier 5 compliant LPG engine technology is incorporated into the gas models in the Logistics range, delivering the reliability, fuel efficiency and power required by the cleanest and most demanding logistics operations.



Precision and control.

In tight industrial areas the Teletruk has the ability to work with precise movement and control to ensure quick and safe handling of the most delicate loads.



Hydrostatic transmission.

All the models in the range benefit from the closed loop hydrostatic drive, delivering precisely the right amount of power to individual wheel motors without the need for a differential or gear-box.





Growing your business.

The Teletruk can save your business space, time and improve saving as much as 30% on operating cost versus traditional methods of loading. In many cases customers have also been able to increase stock holding by 20% supporting profitable growth.

JCB Teletruk dealer champions are ready to calculate the benefits for your business.

STANDARD 2.5 TONNE FORKLIFT VS JCB TELETRUK LOGISTICS MODELS

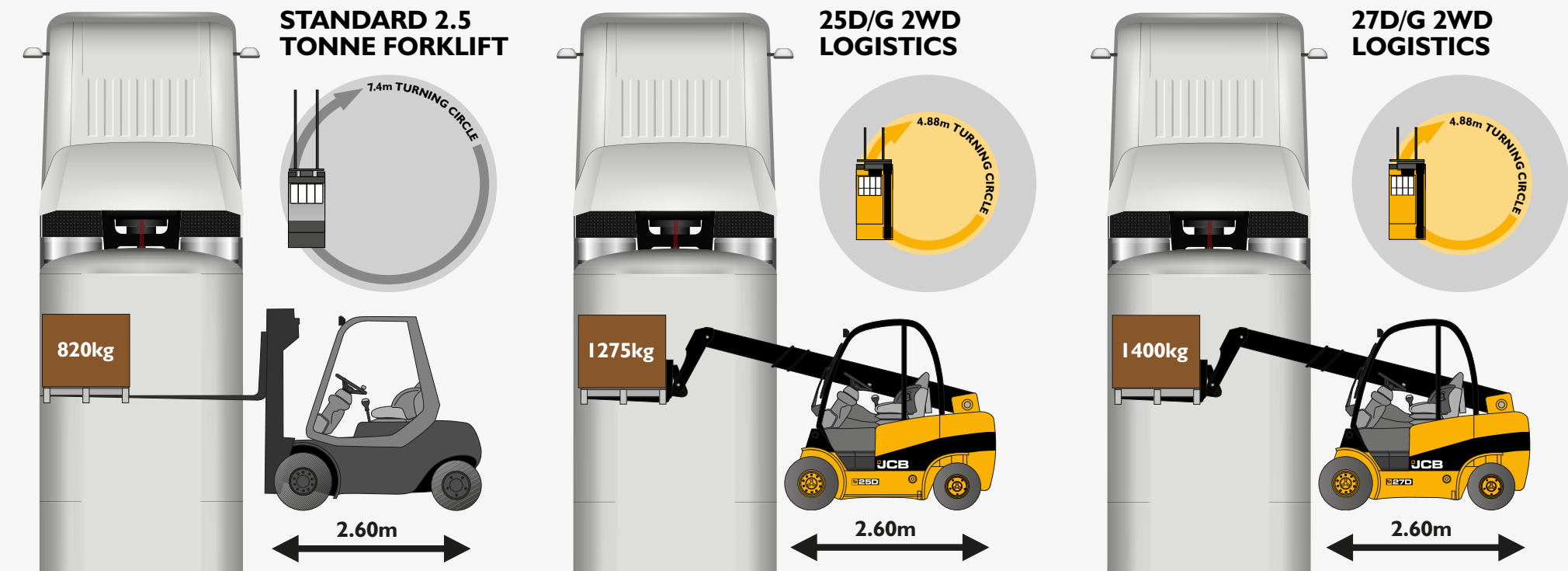

JCB TELETRUK SPECIFICATIONS		25D 2WD LOGISTICS	25G 2WD LOGISTICS	27D 2WD LOGISTICS	27G 2WD LOGISTICS	30D 2WD LOGISTICS	30G 2WD LOGISTICS	30D HL 2WD LOGISTICS	35D 2WD LOGISTICS
Maximum lift capacity	kg	2500	2500	2700	2700	3000	3000	3000	3500
Capacity @ 2m forwards reach	kg	1275	1275	1400	1400	1750	1750	2000	2100
Maximum lift height	mm	4000	4000	4000	4000	4000	4000	5150	4400
Maximum forward reach	mm	2390	2390	2390	2390	2390	2390	3300	2430
Turning radius	mm	2440	2440	2440	2400	2490	2490	2885	2885
Aisle width 90 degree stacking	mm	3940	3940	3940	3940	4005	4005	4475	4480
Overall height (container ready)	mm	2190	2190	2190	2190	2205	2205	2205	2205
Overall width	mm	1175	1175	1175	1175	1280	1280	1280	1280
Unladen weight	kg	4220	4280	4340	4400	4900	4900	5380	5100
Carriage rotation	degrees	111	111	111	111	111	111	111	111
Auxiliary flow rates (low/high)	l/min	28/70	28/70	28/70	28/70	28/70	28/70	28/70	28/70
Negative lift	mm	350	350	350	350	350	350	400	350



Your nearest JCB dealer



www.jcb.com